

The Alma Mater:	Sentry-like o'er lake and valley Towers her regal form Watch and ward forever keeping Braving time and storm	In the music of the waters As they glide along In the murmur of the breezes With their whispered song
Far above Cayuga's waters With its waves of blue Stands our noble Alma Mater Glorious to view	So through clouds of doubt and darkness Gleams her beacon light Fault and error clear revealing Blazing forth the right	In the tuneful chorus blending With each pealing bell One refrain seems oft repeated Hail, all hail, Cornell
<i>(Refrain) Lift the chorus Speed it onward Loud her praises tell Hail to thee our Alma Mater Hail, all hail, Cornell!</i>	To the glory of her founder Rise her stately walls May her sons pay equal tribute Whene'er duty calls	Here, by flood and foaming torrent Gorge and rocky dell Pledge we faith and homage ever To our loved Cornell.
Far above the busy humming Of the bustling town Reared against the arch of heaven Looks she proudly down (Refrain)	When the moments swiftly fleeting Ages roll between Many yet unborn shall hail her Alma Mater, Queen!	May time ne'er efface the memory Of her natal day And her name and fame be honored Far and wide away!

www.commencement.cornell.edu

notes for this year from previous years...

Mike sets chairs in Newman Tuesday! flown speakers in on Monday!!
Mike sets chairs in Barton on Wednesday!! flown speakers in on Tuesday!
Mike is someone else now.

ALL systems MUST be capable of ipod & CD playback ALWAYS and in EVERY CASE, especially if it's not necessarily required just then.

Thursday, May 26

Newman Arena - Hum Ec Graduation walk-through/rehearsal - 9 am
full dress rehearsal with all the trimmings. Diana Brinkman, 255-8053, 342-4676 db274@cornell.edu

Newman Arena - JSGM Graduation walk-through/rehearsal - 11am
Walk thru for students, requires a mic to instruct them. Wireless is nice, but have the podium ready.

Friday, May 27

Arboretum - JSGM Dean's Brunch - set 9am - event 11am-1p

Load in about 9. Set, dressed, and ready by 10:30, a splendid brunch is served by Cornell Catering. Porta-system w/ (4/5) SX300W on poles, FHTR podium w/cornell sign & mics. Presentation occurs around noon. Dress is corporate casual. Generator use is required, no reliable power exists at this location. Setup seems to take about an hour and a half.

New for 2011: generator must be fenced off, single run of SO jacket cable crossing no egress.. event was moved to Sage atrium to avoid threatening weather..

Contact : Ronda Velazquez 254-8828(ofc) 279-7567(cell) rvh2@cornell.edu

Schoellkopf - 9am setup

Schoellkopf - band and chorus rehearsal, convocation walk thrus - 10am-1pm -
see diagram

Schoellkopf - sound check 1:30 pm

for student convocation speakers

Newman - Hum Ec 9:30 am

contact: Dianna Brinkman 255-8053 <db274@> , Eric Kusma 254-5459

Run thru / rehearsal - 10am call

they have trouble hearing on stage!! -talk to client!! this need may be served by an extra spot monitors

Barton - rehearsals - 10am-1pm - WHO IS THIS FOR?

Single mic at podium.. just fire the system up and leave it on, they can talk into it when and if.

Duffield - Trustee Dinner - 5:30-9pm

contact - ??? info- ??? details- ???

A D White House - podium & porta 5:30 - CLIENT? CONTACT #? DRAWING? SETUP?

client and purpose unknown ..

Ramin - Cornell Commtiment/Traditions Bar-B-Q - 5-9, 5:30pm show

contact: Elberta Donahue; Kirsten Gabriel:program coordinator

Food is served. Hangovers sing (VP88; podium mics become solo mics). Students ("fellows") cross stage and speak briefly, requires ducking mic to avoid excessive walking noise. Up/down micing for tall/short students.

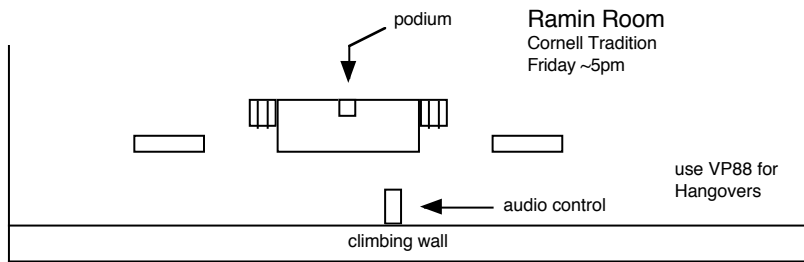

Saturday May 28

note: roads closed in front of schoellkopf ~ 10 - 2

Schoellkopf - Convocation - 12-1.30pm (10 am call)

crew call 10am; utilizes standard stadium system & setup.

Expecting 12,000 seated in crescent and on field. Probably use Barton for foul weather. Band and chorus directors require monitors for to hear each other and light zone micing if they are included.

Arts Quad - Wind Ensemble Concert - 2:45-3:45 pm [morning setup]

- just an announce mic (WITH SWITCH) for conductor (Cindy, or Matt while Cindy is on Sabbatical '09) and a pair of speakers on sticks. South west end of quad. . Snacks are served at adjoining presidents reception. In 2005, the rain plan was activated and the concert was relocated to Barton Hall, where it was performed directly under the stage right cluster with 5 distant mics to a very small crowd.

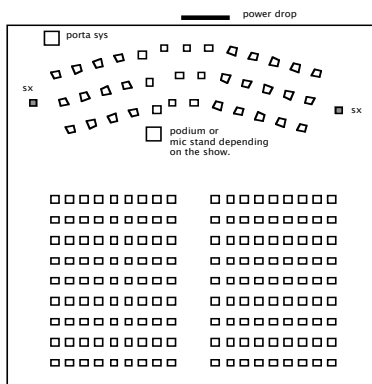

Government / Wind Ensemble / Olin Tent
2 SX/tripods, podium, mic stand & switched mic
switched mic on stand for wind ensemble,
podium w/gooseneck for government

SET Ives Quad - ILR system - see diagram

contact: Kevin Harris @ ILR (see contact list)

Music playback and announcement in quad north of Barton Hall.

SET Government tent near Olin for Sunday

Podium and 2 speaker porta system. same tent and system as wind ensemble previous day.

CLIENT contact # ??

Biology at Lynah 2:30 - 4:00

podium w mic, acapella group: ring of mics plus solo and perc. 2 pop songs & alma mater

Newman Arena - JSGM Graduation - 2:30-4pm

Contact : Ronda Velazquez 254-8828(ofc) 279-7567(cell) rvh2@cornell.edu

audio feed to their videographer, extra mics for 3 singers; more monitors requested in '05 - we supplied 4 on 2 mixes - cross-stage speakers on sticks would be nice. see Rhonda's floor plan at the end of this document.

5/24/10 - Rhonda specified 5 mics on stage - 3 for singers, 1 main podium, 1 for reader, plus processional and recessional CDs, and monitors for faculty and administration..

See following diagram:

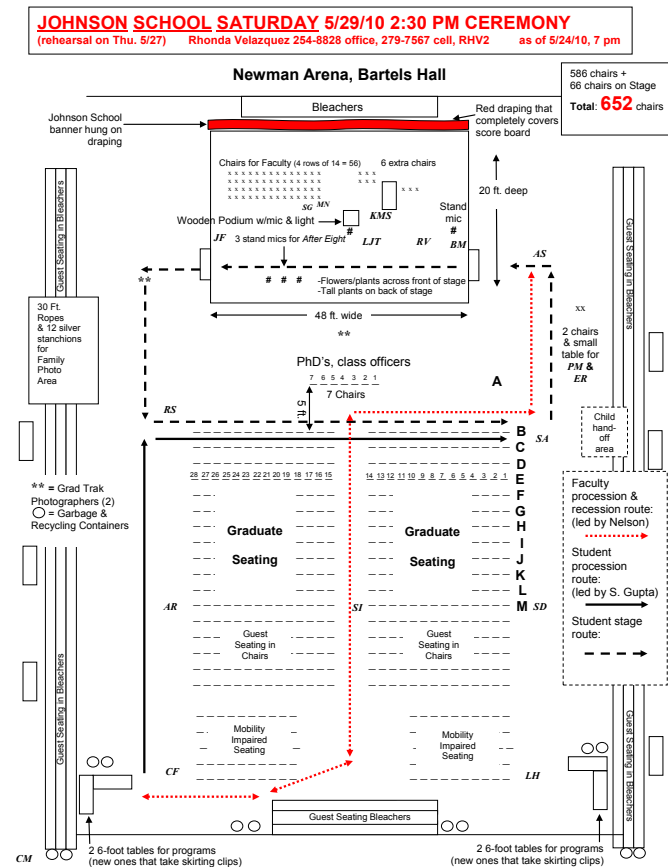

Barton - PHD Ceremony - 5pm-6pm

8-12 mics for wind ensemble, 2 podiums - one for speeches and one to announce the names from.

Archival recording.. Hangovers lead alma mater from podium at end of ceremony prior to processional.

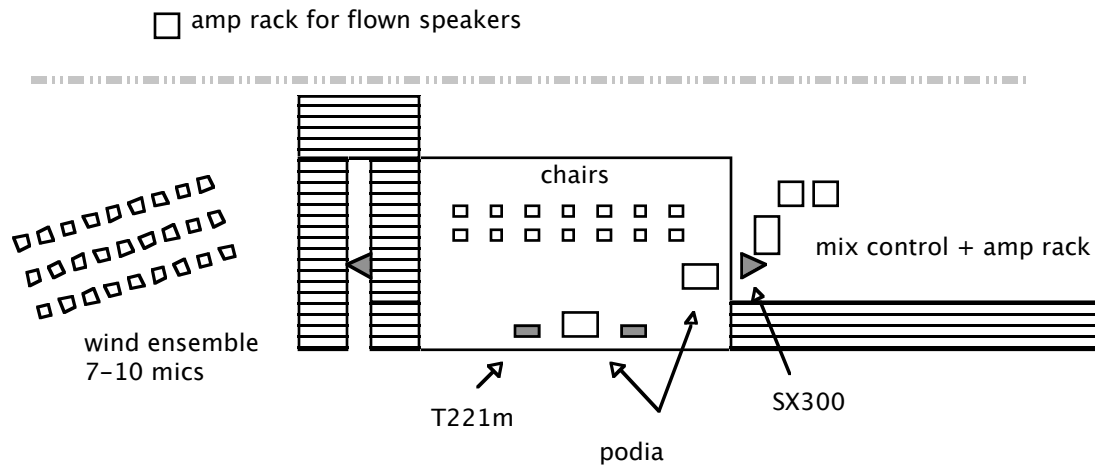

Sunday May 29

note: campus roads around schoellkopf Stadium are closed from 8am
severe weather contingency decision made at 8am also.

Newman Arena - overflow video broadcast from Schoellkopf - 9am - 12noon

Stand by for video from Schoellkopf. Projection TV provided by PCC; sound feed run from projector location.

notes from 08: audio from CIT found in SE area floor pocket; CS212s utilized for side fill in ground stack tipped back; FRXs aimed with 3 holes showing/small clips.. 152 speakers hang at correct angle using 17.5" bridle in front attached to a 13" extension - hey, it worked.

notes '11: two pairs of FRX640s rigged per side, one forward and one splayed out about 45 degrees plus the 152 and some smaller side fill on stix..

Shoellkopf - Graduation Ceremony - 11am-12noon

crew call 6am - check all systems

'doors' 9am - walk in music - CD and then band w/ announcer

requires a person on intercom at all times from 9:30-ish to noon to relay directives from the powers that be. Handled by a 3 or 4 man crew for show (mix eng, sys eng, intercom guy, runner/setup guy)

Ramin - Civil Engineering - about 12:30pm

contact: Jeanette Little 255-3690

1 podium mic. Monitors for students on risers to hear their name being called. (see diagram for Biology honors ceremony Saturday afternoon)

Arts Quad, McGraw Tent - Architecture, Art, & Planning - about 12:30pm

contact: Beth Kunz <egk7@> 255-7324

2005 : Tent is available from 5pm Saturday; 80 x 230 tent, 1700 people, stage set on long side of tent

2 mics for strings, 1 podium mic, minimum 6 speakers on sticks, longish cables

Ives Quad - ILR - about 12:15

an outdoor event in the quad to the north of Barton Hall - multiple tents, two outside stacks.. mostly announcements, we think... the crowd moved directly to the following gig:

Lynah Rink - ILR - 1pm-ish

2 flown FRX-94 boxes for mains plus 2 1152-94 for fill over the glass plus some plasti-boxes for fill in upper tier seating, a monitor or two plus front fill; 3 mics.

Barton - Hotel School - about 12:30pm

contact: Jeff Hetzel, Rick Wood, Cheri Farrell 255-6376, Dina Kristof 255-7245

tech up by 11:30am

Pictures are taken of each grad. . 5 mics for brass, 2 podium mics.

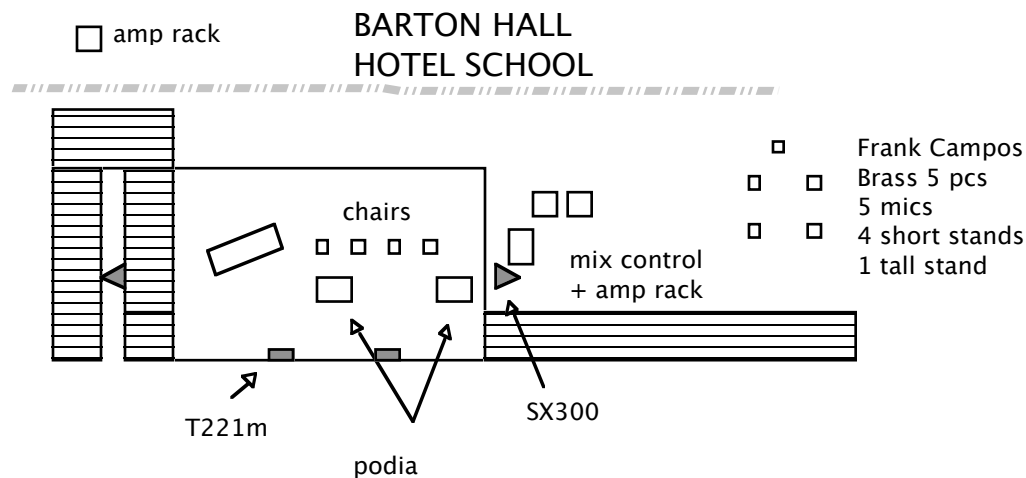

<= 2009 setup

Newman - Human Ecology - 12:30pm

contact: Dianna Brinkman 255-8053 <db274@> , Eirc Kusma 254-5459

THEY HAVE TROUBLE HEARING ONSTAGE!! MORE MONITORS!! DOUBLE CHECK MUSICAL PROGRAM!!

brass quintet. speeches. reading of names. We have intercom listed, but that's really just because they can't hear onstage.. advance this problem, and fix it.

Olin Tent - Government - 12:30 - described as 'near Olin'

contact: ????

2 SX on poles + ports sys; we supply podium & podium mic.

Misc - Strike all systems, leaving stuff flying per Barny's direction for use on subsequent jobs during reunions. Take monday off.

Contact Numbers:

Cornell -

Connie Mabry - Director of Commencement Events

255-9541, 254-8237(office) 255-9541(cell) cbm1@cornell.edu

Joe Lalley - Dir Business Ops, Facilities Management 255-4394(office) jml2@cornell.edu

Command Center, Barton Hall - 255-7775

Bill Youst - Carpenter shop - 327-0543 - wy25@

Bill Wilcox - Carpenter shop - 327-3321 - waw7@

Mike Goodwin - Building Care - Barton Hall - 592-0606

Henry Crans - Arts Quad Coordinator - 255-3801, 227-5815(cell)

Dan Robinson - electric shop - 327-0512

Frank Davenport - electric shop - 327-2623

Tim Diamond - electric shop - 327-1423 - tmd9@

Geneva Tent - tent rentals - 315-789-3151, 315-347-6591(tom cell)

Athletics - Matt Coats 255-1814 (athletic facilities: Ramin, Newman, etc.)

Departments

Architecture Arts & Planning - Beth Kunz - 255-7324 <egk7@>

Biology - (Carol Carr 255-5233) // Amy Haner 255-5233, 315-730-3370

Civil Engineering - Jeanette Little 255-3690

Government - ??????

History - Maggie Edwards 255-4376

Hotel School - Cheri Farrell 255-6376 <cfs7@cornell.edu>, Dina Kristof 255-7245

Human Ecology - Dianna Brinkman 255-8053 <db274@>, Eirc Kusma 254-5459

ILR - Kevin Harris - 280-2746(cell) 255-1518(ofc)

JSGM - Ronda Velazquez - Johnson School Events Organizer 254-8828(ofc) 279-7567(cell)
<rvh2@cornell.edu>

JSGM - Jenn Cottrell -254-5446 <jlf27@cornell.edu>

Calf Staff

Barny Cole 272-8964(ofc) 280-3723(cell) barny@calfaudio.com

Todd Hutchinson 387-5380(home) 342-8395(cell) todd@calfaudio.com

Greg McGrath 585-329-6626(cell) monksound@mac.com
Chris Martin 573-499-9465 chrismartinmusic@gmail.com
Isaac Derfel
Kenny Christianson
Dan Polangoli
Mike Garrett
Sam

road

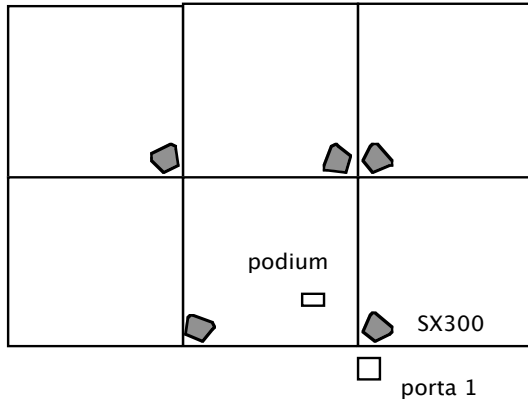

JSGM Deans brunch
tents 30' square
42' diagonal
layout varies slightly
year to year - see
Rhonda's diagram

podium, speaking,
light jazz playback
(we provide)



generator

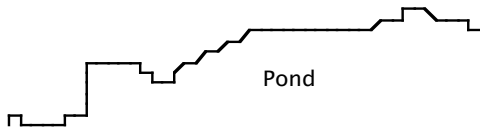

Pond

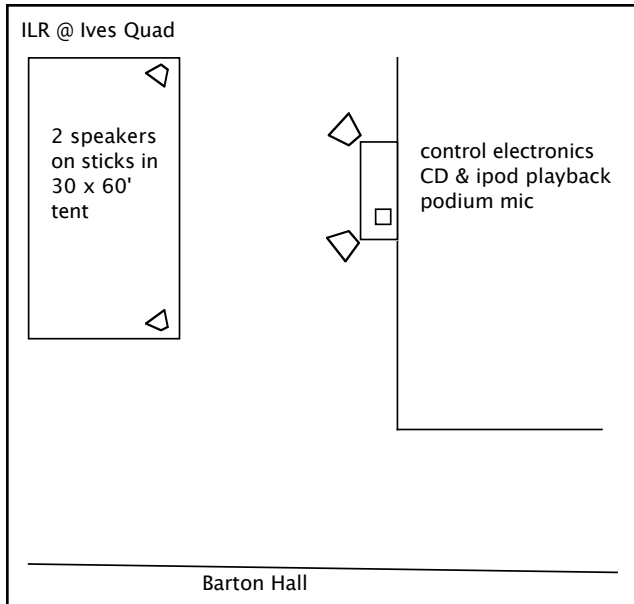

ILR - IVES QUAD - Announcement and music playback

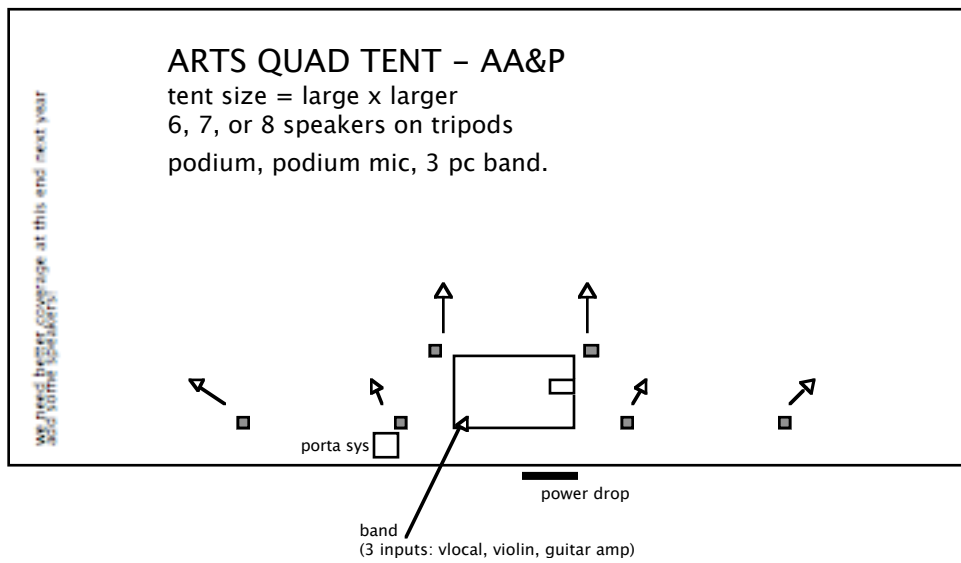

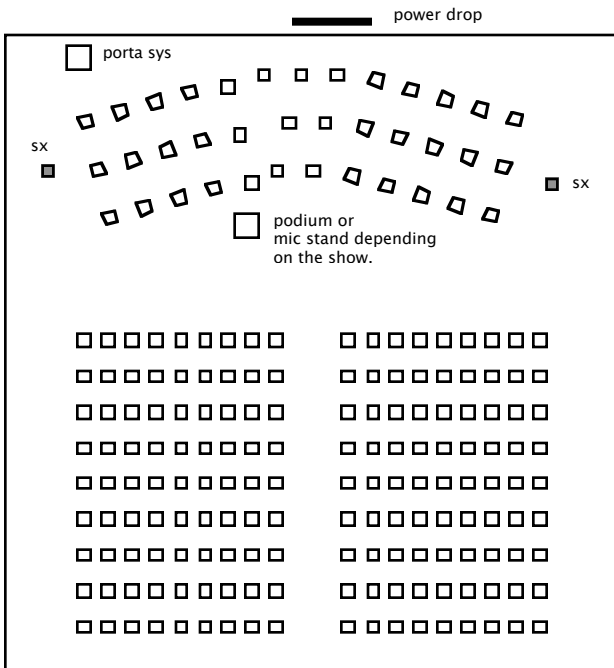

Government / Wind Ensemble / Olin Tent

2 SX/tripods, podium, mic stand & switched mic
 switched mic on stand for wind ensemble,
 podium w/gooseneck for government

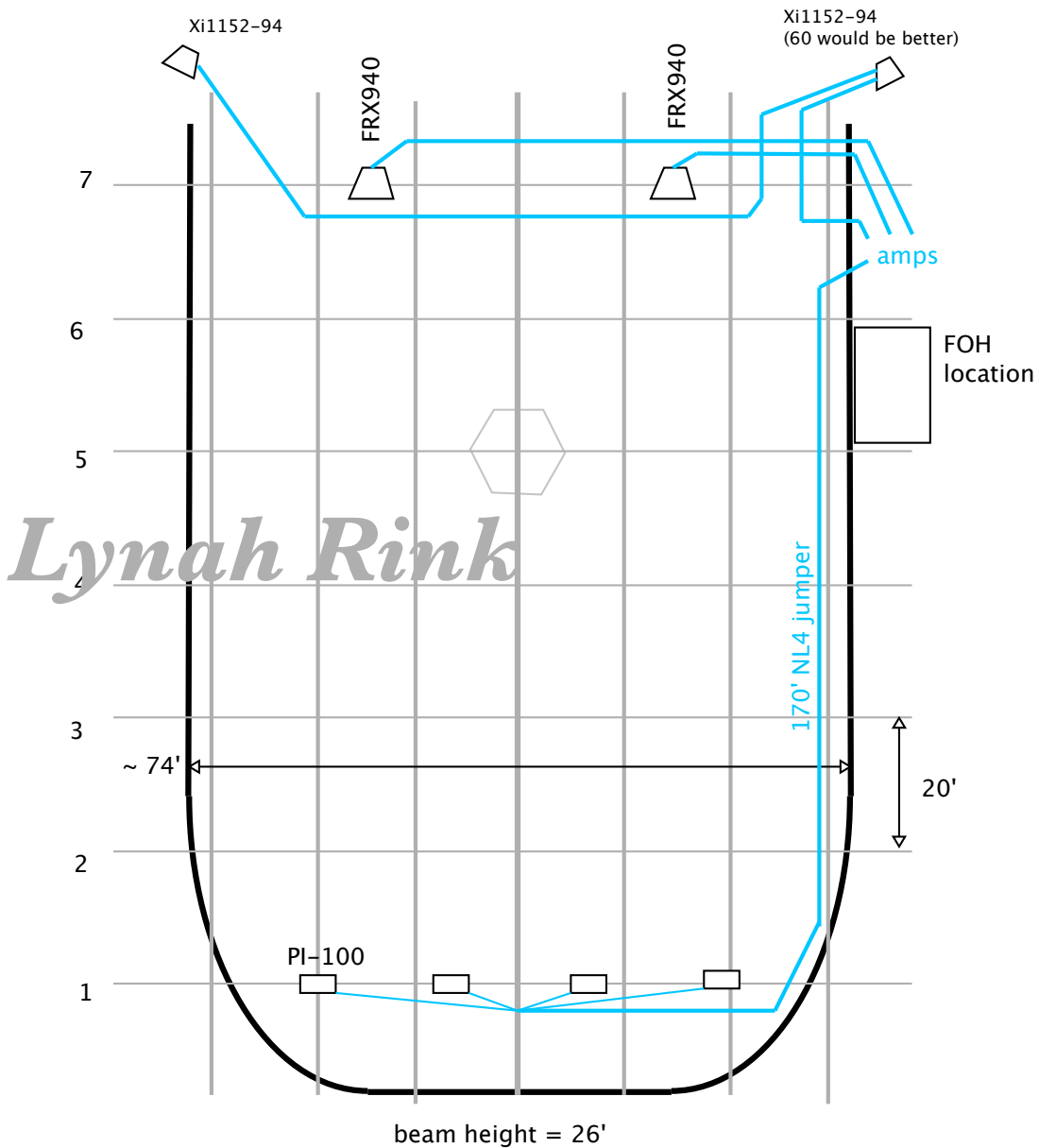

LYNAH RINK

- 1 Lake processor
- 1 Q66 x 4 rack
- 1 desk
- 1 EQ
- podium, mic; acapella group ~ 6 solo + group ring
- 2 Xi1152
- 2 FRX 940
- 4 PI-100
- 4 (XW12 or T221M) monitor

BARTON HALL - 2009: FRX 640 substituted for the two SX300s; hang point over 6th hole, biamped.. it could have hung a little more steeply, try 5th or 4th hole next time..
also, I'd like to completely re-hang all those points... well, have someone do it..

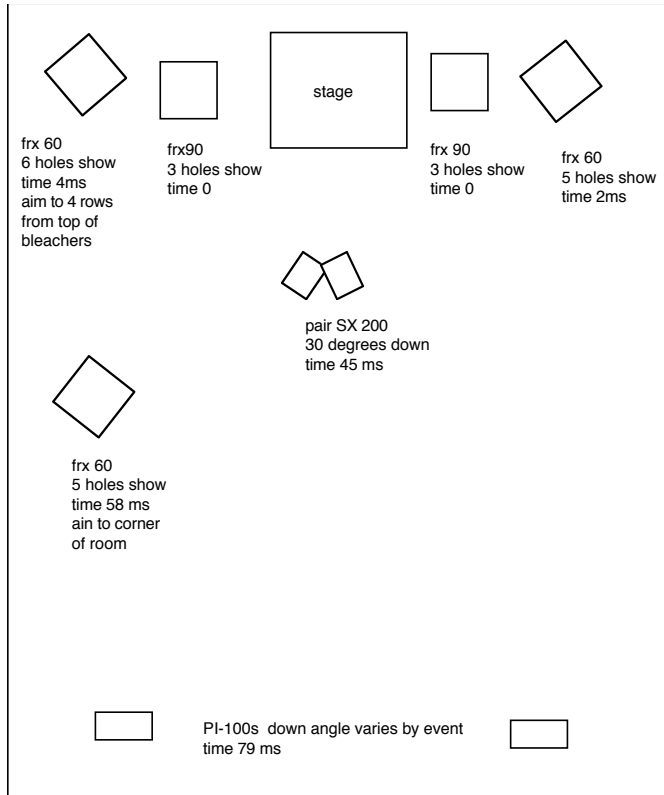

Barton basic speaker layout with rigging points for FRX & delay times noted.

Barton Hall

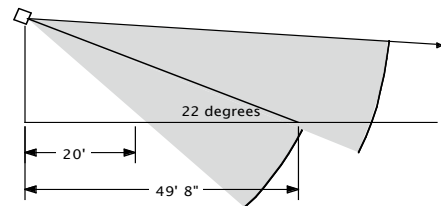
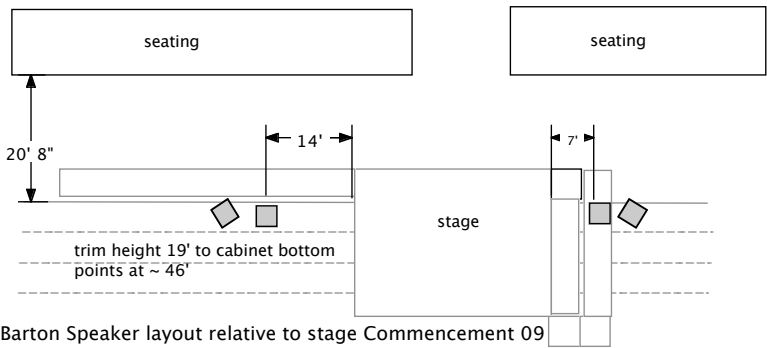
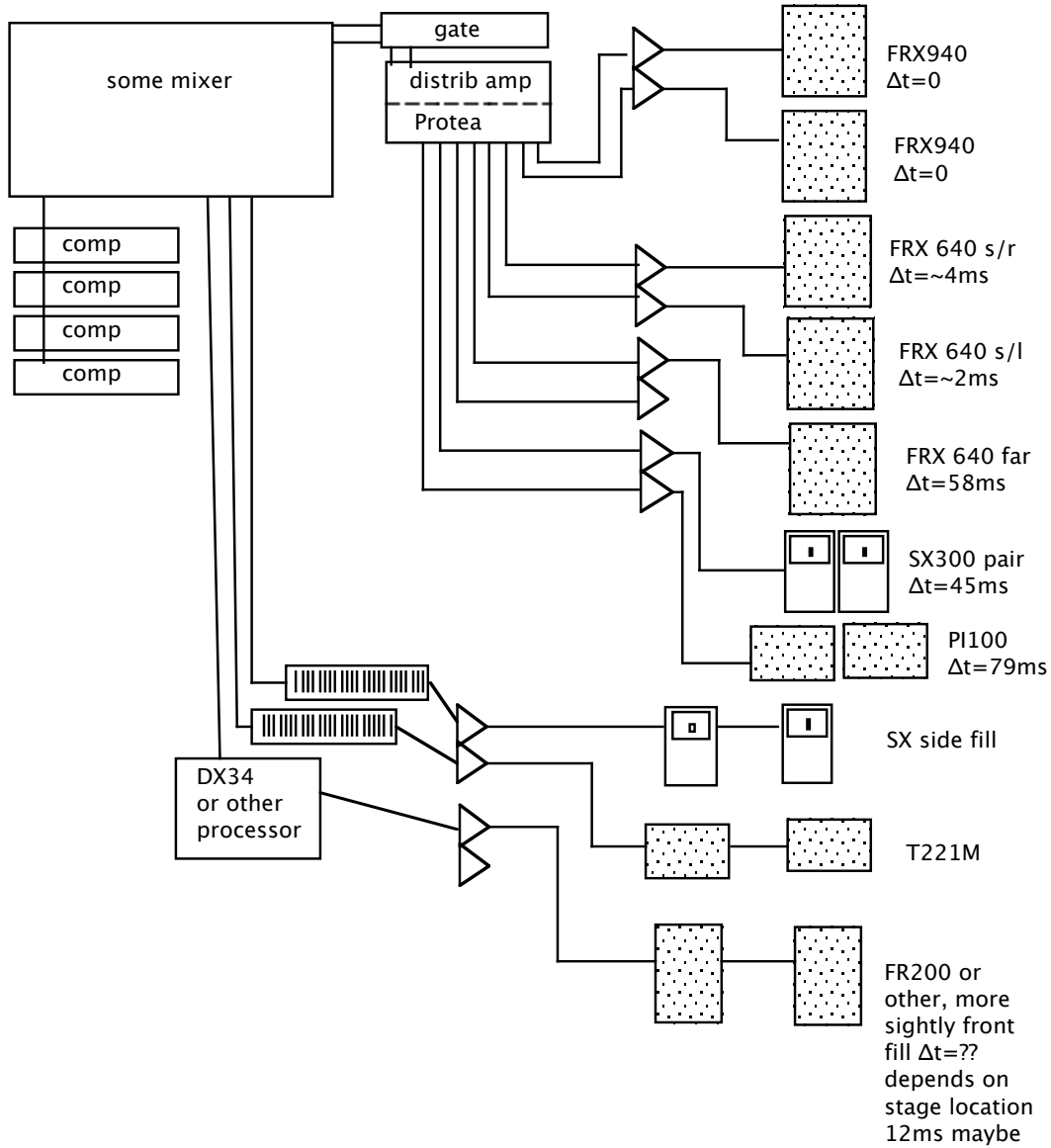

NEWMAN Commencement system

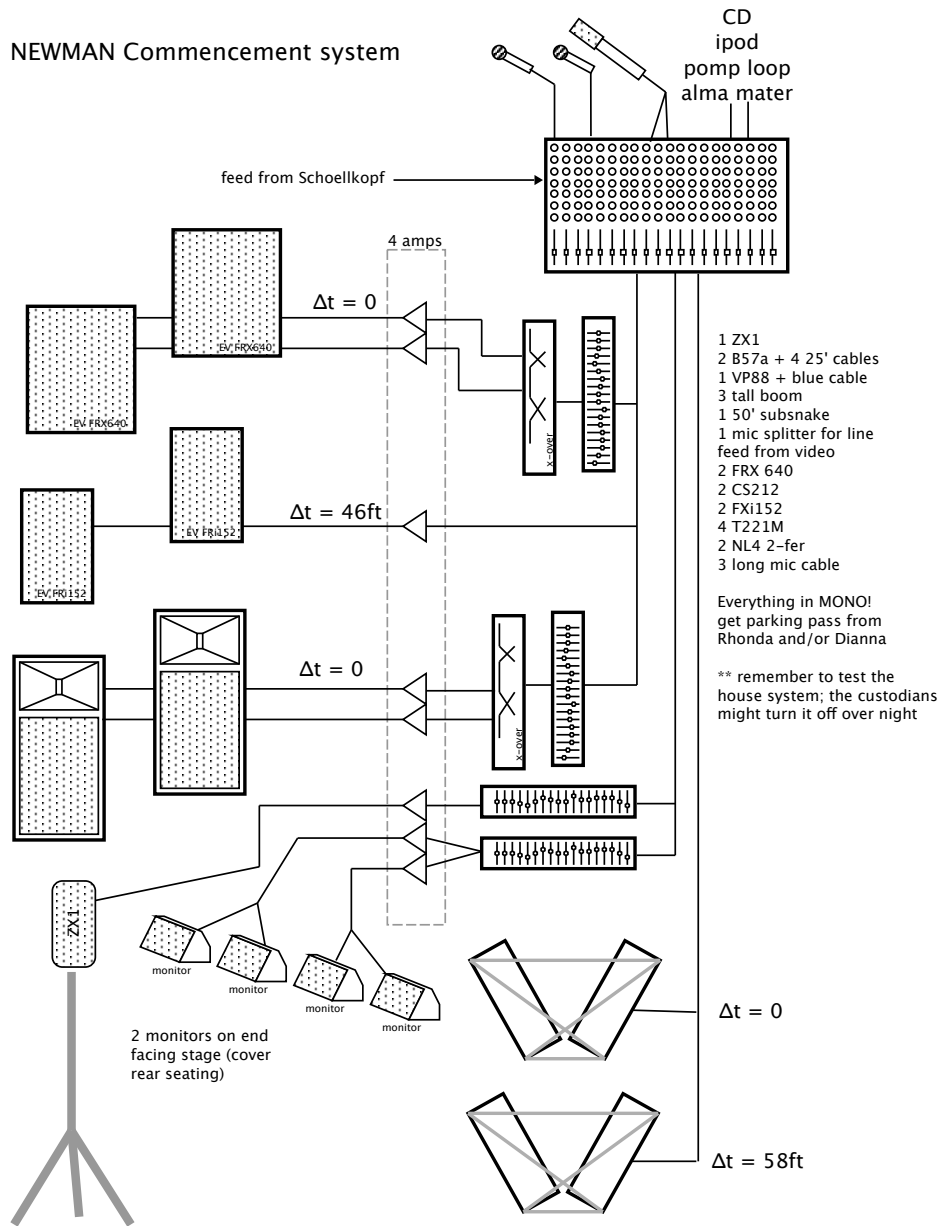

* note - the north house system has a time delay conflict with flown mains; it can't be right, and would be better to fly another set of speakers coincident with the front mains to cover the north end of the bleacher seating. The south end seems less critical, although again, because of the placement/origin of the various speaker systems, there is no right way to time it.

* also note: this system done in 2011 with a pair of FRX640s (passive mode) flown splayed instead of the CS212 for side coverage.

RAMIN ROOM

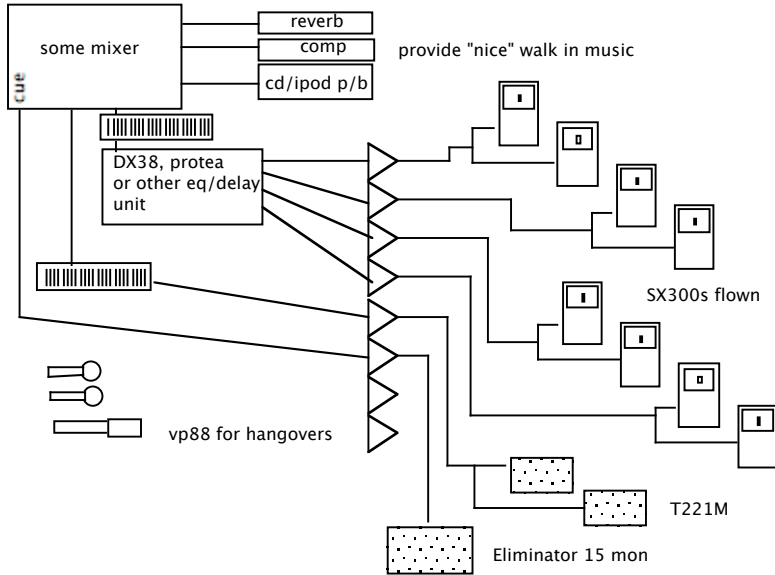

delay setting for second row = 40'

installed wires fitted with NL4

front speakers wired inside/outside pair, rear speakers paired left-right..

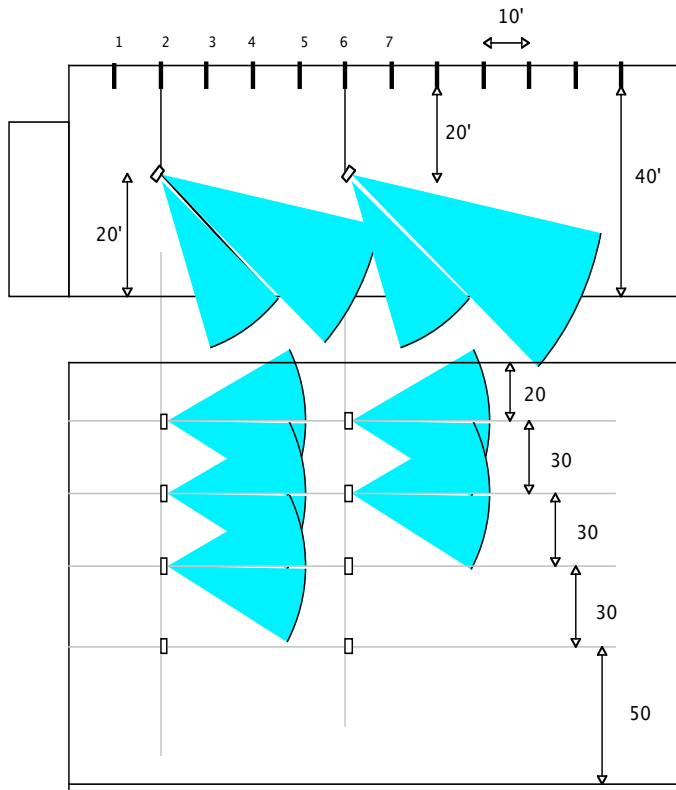

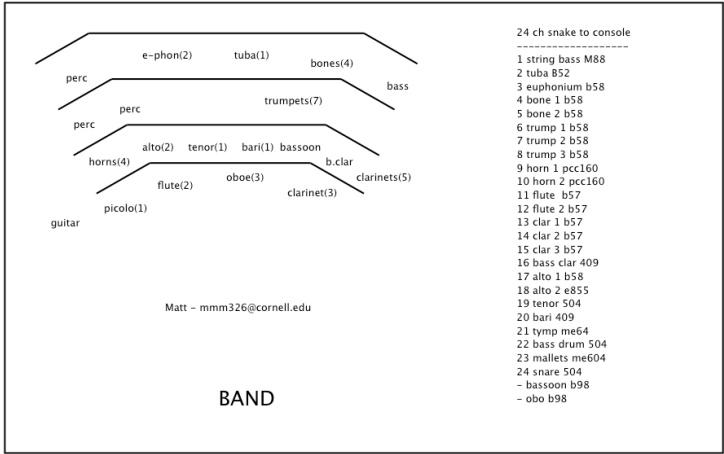
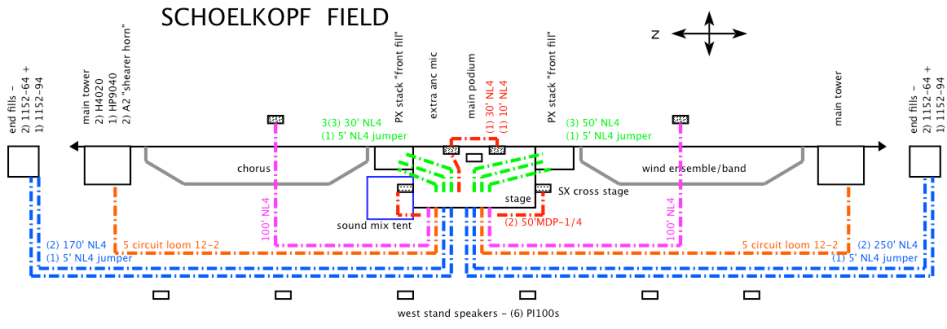

- 24 ch snake to console
- 1 string bass M88
 - 2 tuba B52
 - 3 euphonium b58
 - 4 bone 1 b58
 - 5 bone 2 b58
 - 6 trump 1 b58
 - 7 trump 2 b58
 - 8 trump 3 b58
 - 9 horn 1 pcc160
 - 10 horn 2 pcc160
 - 11 flute b57
 - 12 flute 2 b57
 - 13 clar 1 b57
 - 14 clar 2 b57
 - 15 clar 3 b57
 - 16 bass clar 409
 - 17 alto 1 b58
 - 18 alto 2 e855
 - 19 tenor 504
 - 20 bari 409
 - 21 tympanon me64
 - 22 bass drum 504
 - 23 mallets me604
 - 24 snare 504
 - bassoon b98
 - obo b98

- Chris' Cable Count**
- NL4**
- 250' x 2
 - 170' x 2
 - 100' x 2
 - 50' x 4
 - 30' x 4
 - 5-10' x 5
- banana-1/4 or NL4**
- 50' x 2
- tower looms**
- loom x 2 (bundled & labeled)

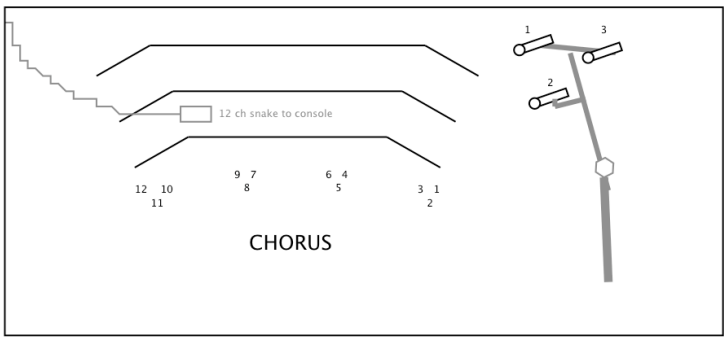

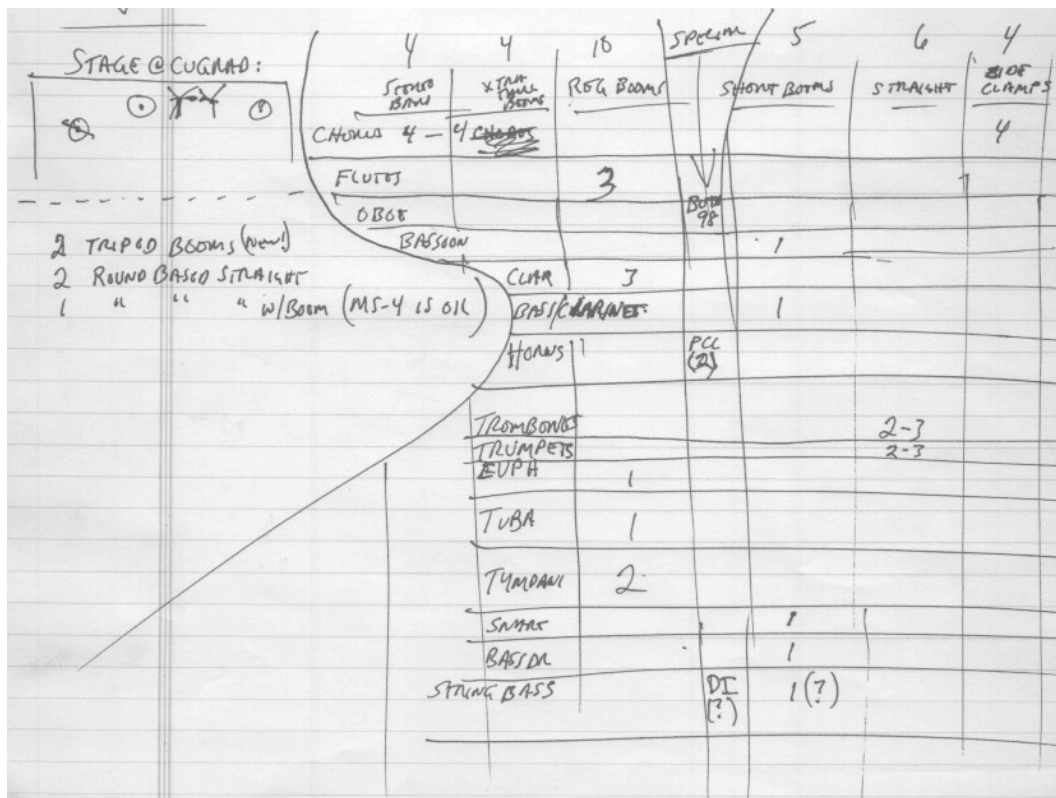

barny's 2010 notes

nominal Schoellkopf Field Input List - please correct and return

mics

- 1-26 wind ensemble
- 27-39 chorus mic stand inputs
- 40-41 wireless lavs on basses in chorus
- 43 podium sr
- 44 podium sc
- 45 podium sl
- 46 announcer
- 47 god mic
- 48 wireless emergency mic

stands:

- xtra-tall booms 4
- regular booms 10
- short booms 5
- strait stands 6
- stereo bars 4
- side-clamps 4
- b98 2

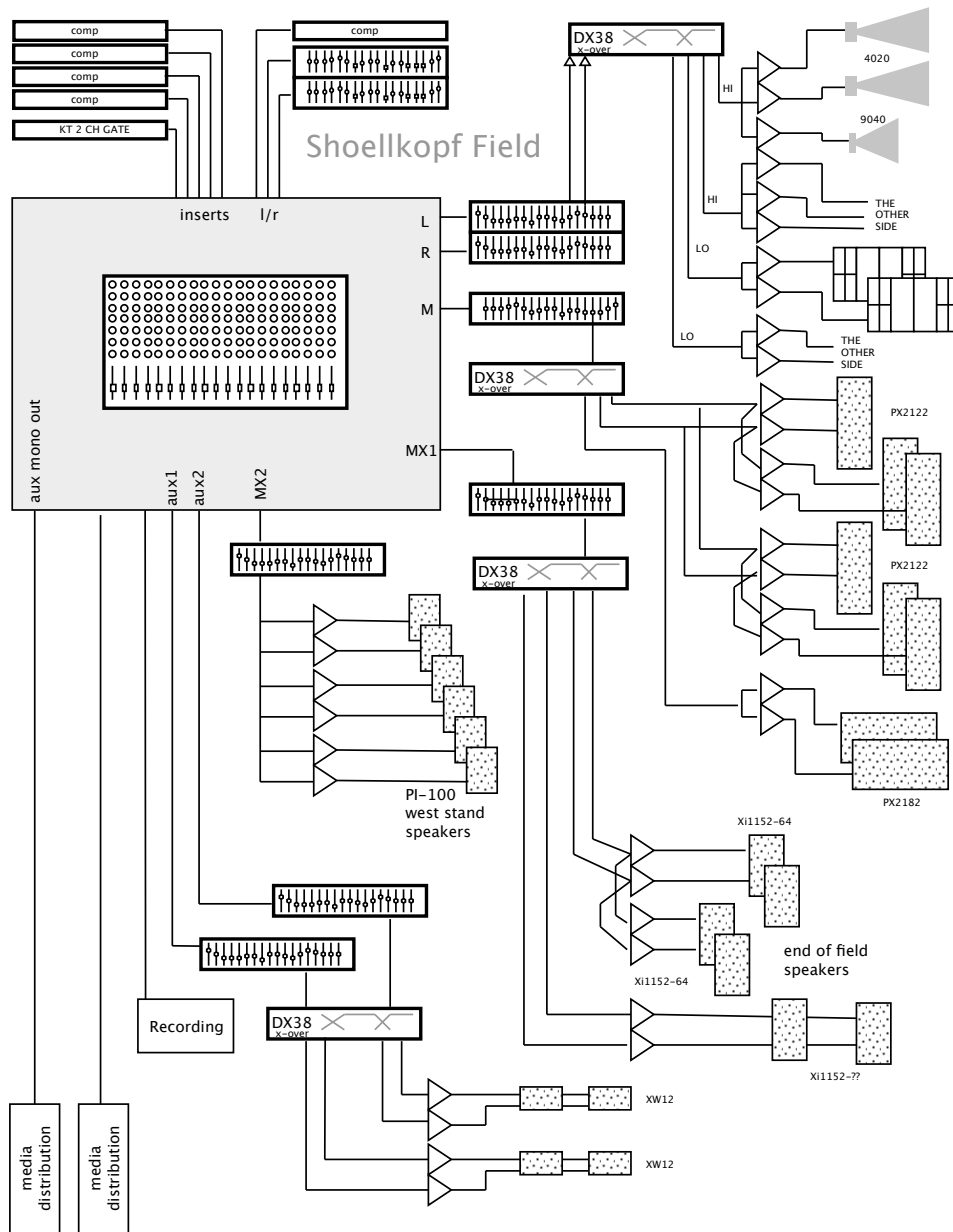

Requested by video: automatic ducking on music submasters keyed on announce mic

Venue	Schoellkopf	Barton	Newman	Lynah	Ramin	Ives
A1	HBC	JTH	GM	CM	Dan	??
A2-A4						

	MONDAY	TUESDAY	WEDNESDAY	THURSDAY	
7					
8	call: 8:30 am East Hill Plaza	call: 8:30 am East Hill Plaza	call: 8:30 am East Hill Plaza	call: 8:30 am East Hill Plaza	
9	Distribute equipment	<div style="border: 1px solid black; border-radius: 50%; padding: 10px; text-align: center;"> complete Barton (mike sets chairs wednesday am) hang Ramin </div>	<div style="border: 1px solid black; border-radius: 50%; padding: 10px; text-align: center;"> complete Ramin complete Schoelkopf complete Lynah </div>	<div style="border: 1px solid black; padding: 5px;"> Hum Ec Walk-thru Newman 8:30-11 </div>	
10					<div style="border: 1px solid black; padding: 5px;"> JSJM Walk-thru Newman 11-12 </div>
11					
12					
1					
2					
3	<div style="border: 1px solid black; border-radius: 50%; padding: 10px; text-align: center;"> Complete Newman hang (mike sets chairs tuesday am) </div>				
4					
5					
6					
7					
8					

FRIDAY 2010

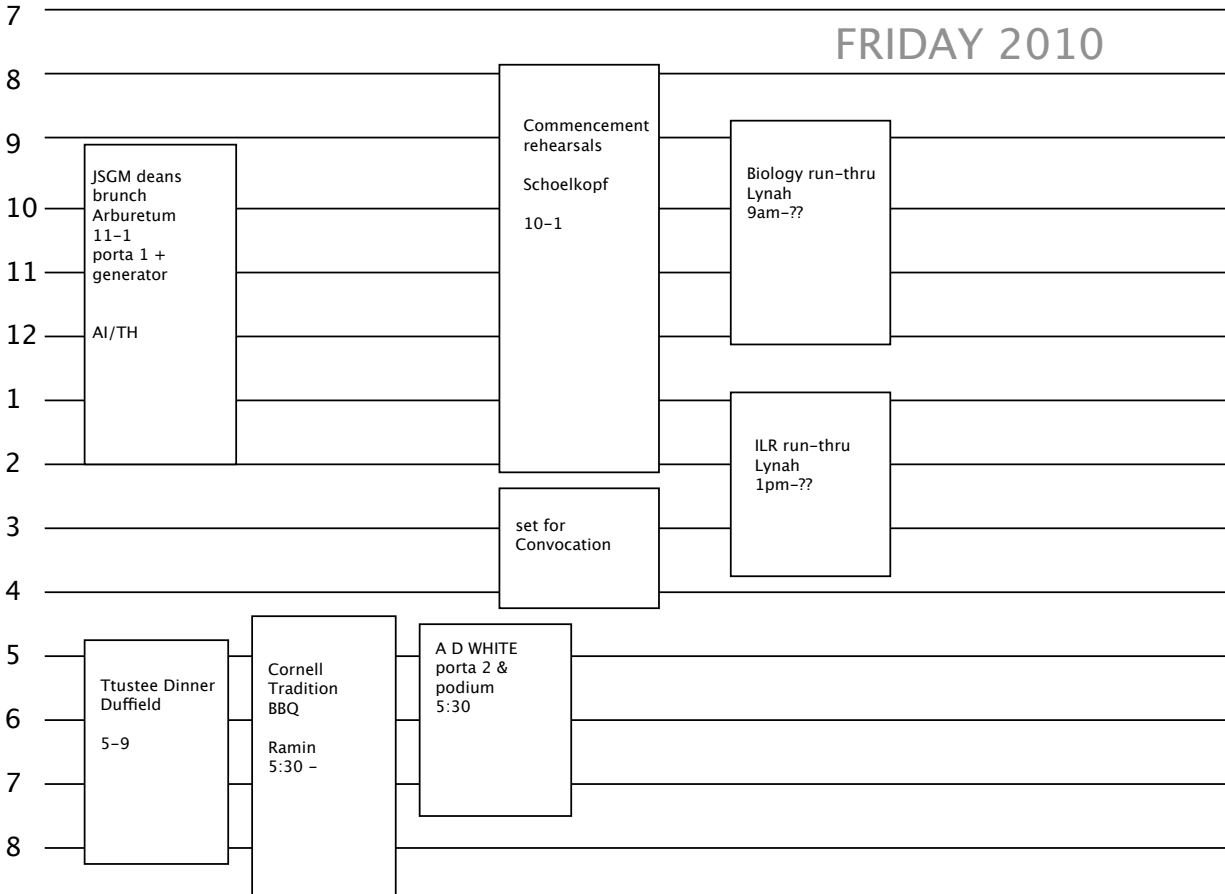

SATURDAY 2010

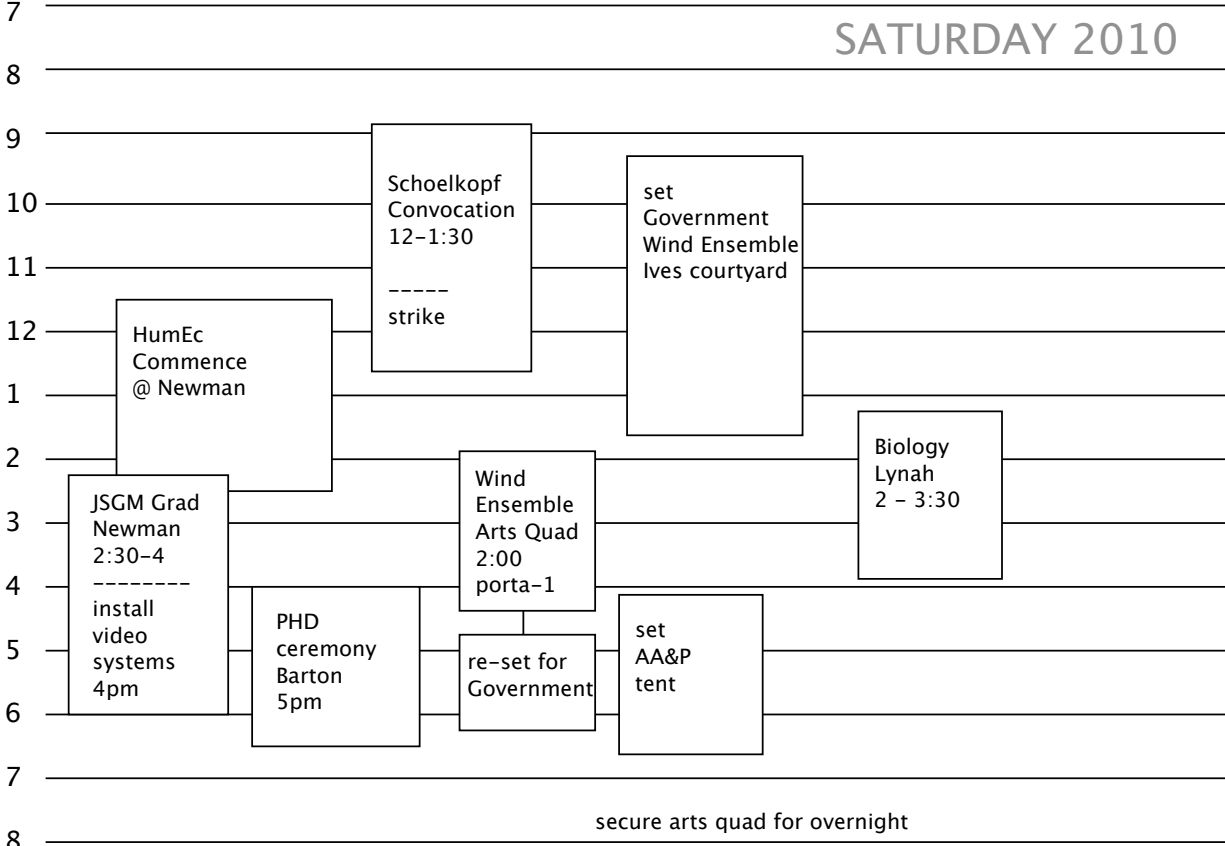

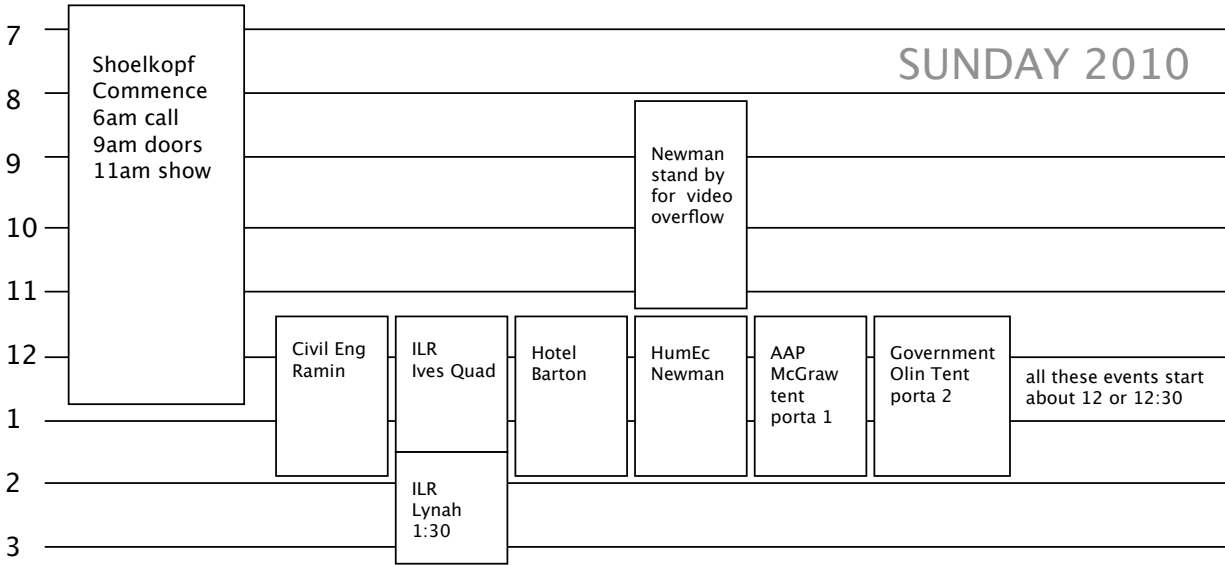

4 —

5 —

6 —

7 —

8 —

ALL STRIKE
(leave barton flying stuff in place)

(dinner)